



Within the range of suppliers TRAPOROL GmbH maintains its prominent position at the market with high-quality products and innovative new developments. Modular conveyors, accessories as well as extension components for complete materials-handling installations are adapted in size, material or surface texture to the respective requirements of the industry and the customer.

Close co-operation and continuous information exchange with customers creates a secured basis for user-referred and customer-oriented new and further developments.

Most modern manufacturing plants and production methods ensure

thereby the problem-free, fast conversion of transportation problems to practicable solutions.

By close co-operation between engineers, developers, technicians and users, standard components are continuously improved and the development is advanced by product novelties.

Our experience as well as the unflagging commitment of our employees is reflected in the quality of our products. Only if the customer is satisfied with our product, we are satisfied as well.



**TRAPOROL** GmbH

The supporting roll in materials-handling technology

SMOOTH IN EVERY DIRECTION

FULL POWER WITH THE RIGHT PARTNER



The All-Side Roller

As a versatile usable module for low-friction distributing, transporting, turning and shuffling-off the All-Side Roller is the perfect optimization for your material flow.

**TRAPOROL GmbH**

Industriestraße 1  
48712 Gescher-Hochmoor  
Germany

Phone +49 (0) 28 63 / 92 42 30

Fax +49 (0) 28 63 / 92 42 59

[www.traporol.de](http://www.traporol.de)

[info@traporol.de](mailto:info@traporol.de)

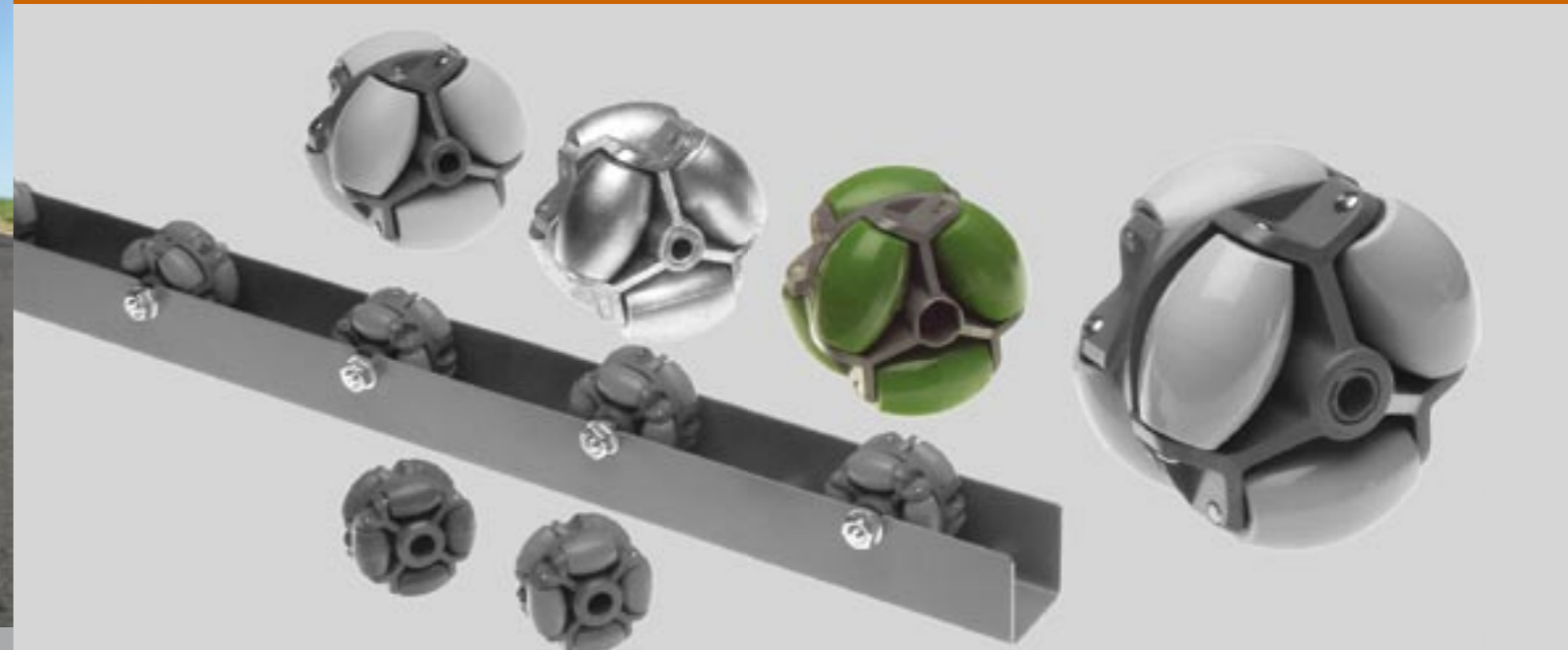

**TRAPOROL** GmbH

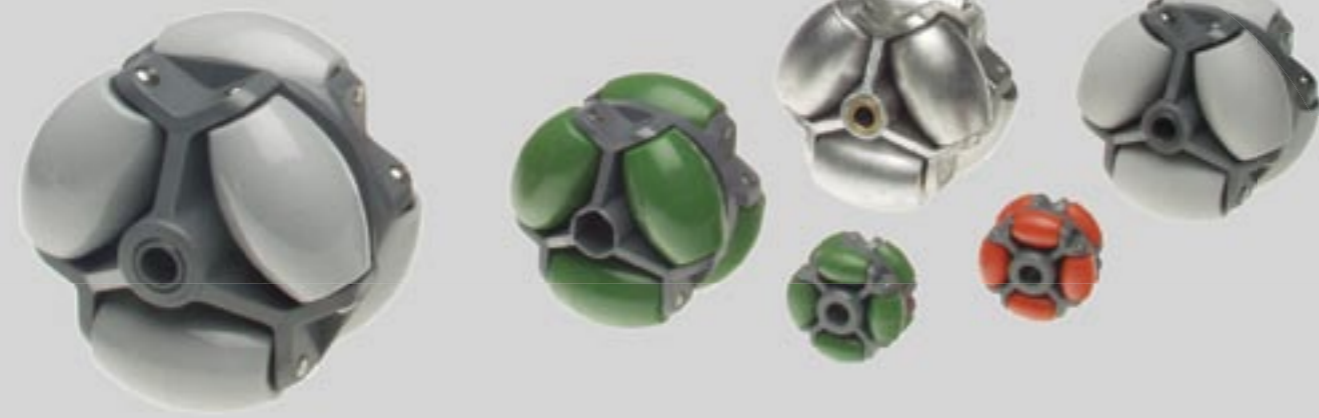

## THE ALL-SIDE ROLLER

The all-side roller is a self-development, one of many examples of creative know-how for the extension of the broadly strewn product range.

As a versatile usable module for low-friction distributing, transporting, turning and shuffling-off the All-Side Roller is made to optimize your material flow.

## PRODUCT CONVEYING & EASY TRANSFERS IN ANY DIRECTION

All-side Rollers enable flat-surface unit loads to be rotated on their own axis (360°) in any desired direction for smooth multi-directional handling. An extreme facilitation especially for transport lines with collateral handing in, turning or rolling off with different sizes and weights of the respective material.

Because of the versatility of the All-Side Roller conveying or flow direc-

tion remains stable until the operator or plant personnel initiates a directional change. Thus the All-Side Roller as a robust component offers ideal product attributes for optimized material flow and can be used for self-assembly as a construction component in every size.



## FROM INDIVIDUAL COMPONENTS TO FULL CUSTOM-BUILT SYSTEMS

TRAPOROL offers customers individual roller components, single- and multi-roller-racks, transfer tables or custom-designed and built systems for handling, sorting and/or processing applications.

The universality and flexibility of the unique All-Side Roller enable its use in a variety of production and packaging applications.

The team of TRAPOROL is always available in case you have any questions about this materials-handling component.



## TECHNICAL DETAILS

- The All-Side Roller is available in diameters of 40, 48, 60, 80 and 120 mm
- Barrels mounted with stainless steel (1.4104) axle
- Maximum carrying capacity 10,15, 20, 40, 120 daN (15, 25, 50, 100 and 225 lbs)
- All-Side Rollers can be used for manual or driven transport



## SCHEMATIC VIEW OF TRANSFER TABLE

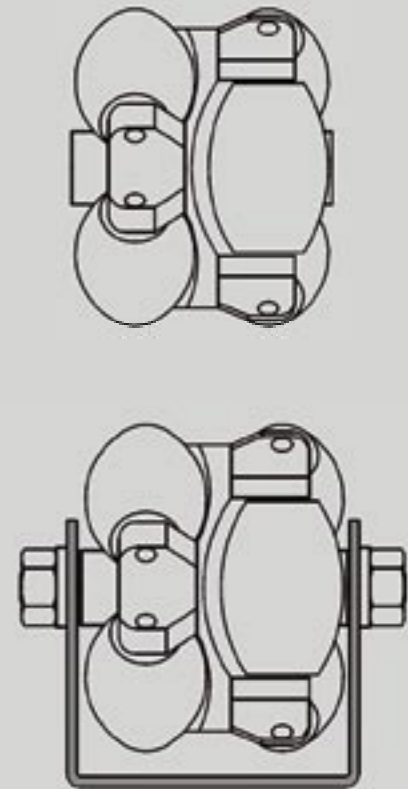
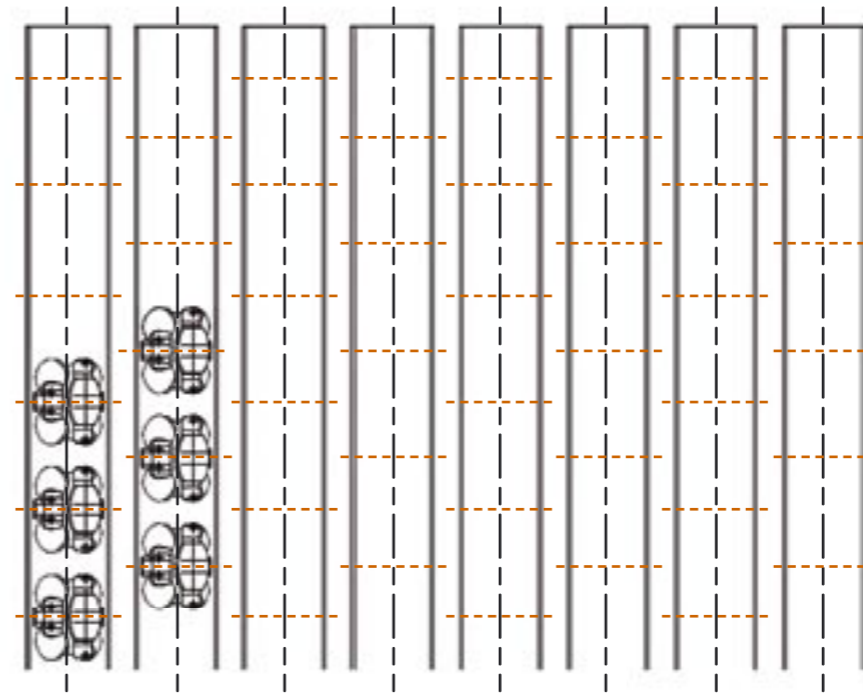

## DIMENSIONS

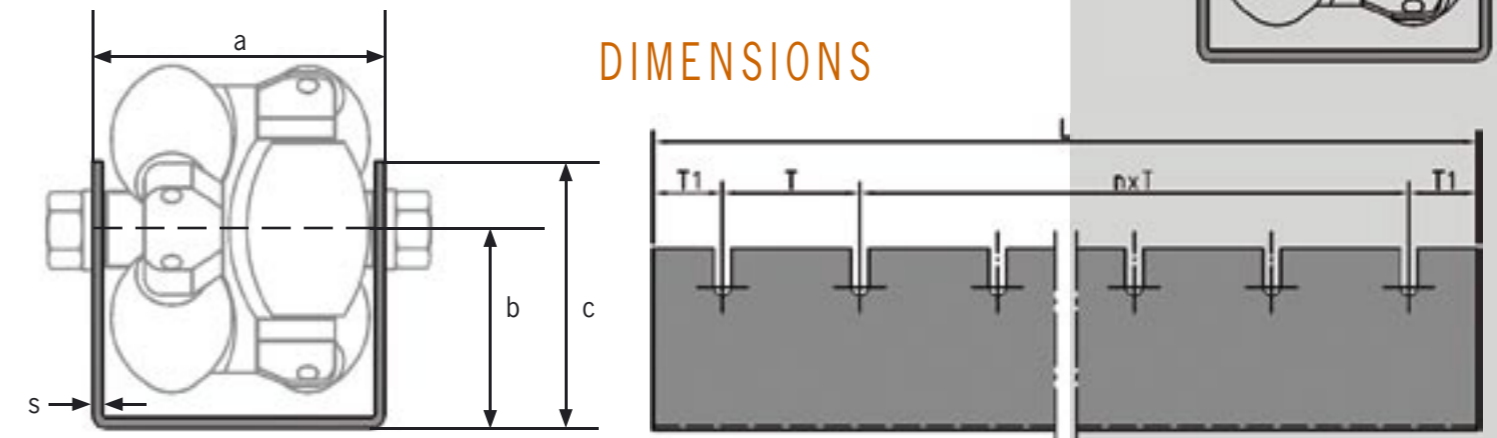

Model Type	a	b	c	s	T	T <sub>1</sub>	
						A	B
ARP40	34	33	26	1,5	50	25	50
ARP 48	44	40	30	1,5	100	50	100
ARP 60	57	50	40	2,0	100	50	100
ARP 80	73	60	50	2,0	100	50	100
ARP 120	106	85	70	4,0	150	75	150

## COMPONENTS FOR SELF-ASSEMBLY

By request custom manufactured

- Conveyors
- Transfer tables
- Rails
- All-Side Roller strips